

ORBIT

CRANE WEIGHER

ORION
ENGINEERING WEIGH

Lift Your Profitability **ORBIT**



DIMENSIONS :

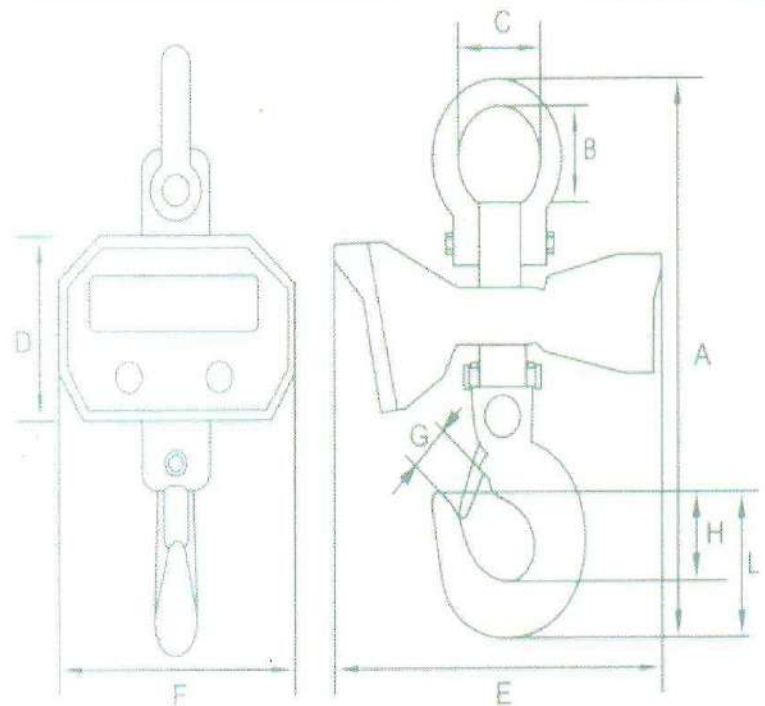

- Ideally suited for foundries, Steel yards laddle weightment.
- Available with temperature shield for high temperature weightment in foundries, steel industries.

CAPACITY	ACCURACY	NET WEIGHT(kg)	A (mm)	B (mm)	C (mm)	D (mm)	E (mm)	F (mm)	G (mm)	H (mm)
1T	200g	14	560	100	55	160	340	235	40	23
2T	500g	14	560	100	55	160	340	235	40	23
3	500g	14	560	100	55	160	340	235	40	23
5	1kg	25	710	120	90	160	340	235	50	32
10	2Kg	36	850	120	90	160	340	235	60	32
15	2Kg	60	980	210	135	160	340	235	90	47
20	5kg	65	1030	210	135	160	340	235	90	47

ORBIT CRANE WEIGHER

ORION
ENGINEERING WEIGH



SPECIFICATIONS

- Bright Green / RED LED Display
- Rugged Construction
- Suitable for foundries, Steel yards, Ladle weighments.
- Instant rechargeable battery.
- Remote Control for user friendly operations.
- Durable, Reliable, Accurate & Affordable.
- RS232 Interface.

CAPACITY	ACCURACY
200kg	0.1 kg/0.05 kg
300kg	0.2 kg/0.1kg
500kg	0.2 kg / 0.1 kg
1000kg	0.5 kg / 0.2 kg



- Crane Scale with Heat Shield for use in foundry, ladle weighment
- Dimensions & Capacity like crane scale shown on other page.

DEAR CUSTOMER,
WE HAVE MOVED TO A
BIG STATE OF THE ART
MANUFACTURING UNIT



PLEASE NOTE OUR
CONTACT DETAILS :

POST CARD

ORION AUTOMATION SYSTEMS

39, 7th Main, J.C. Industrial Estate

Kanakapura Road, Bangalore - 62.

Tel : +91-80-26860 081 / 82

Fax : +91-80-2686 0081

E-mail : ssrao@satyam.net.in

www.orionscales.co.in

www.orionscales.com

PROVEN
1991
SINCE